

Parts List for Dual Bottle Carrier

HX-1050
Dual Bottle Carrier

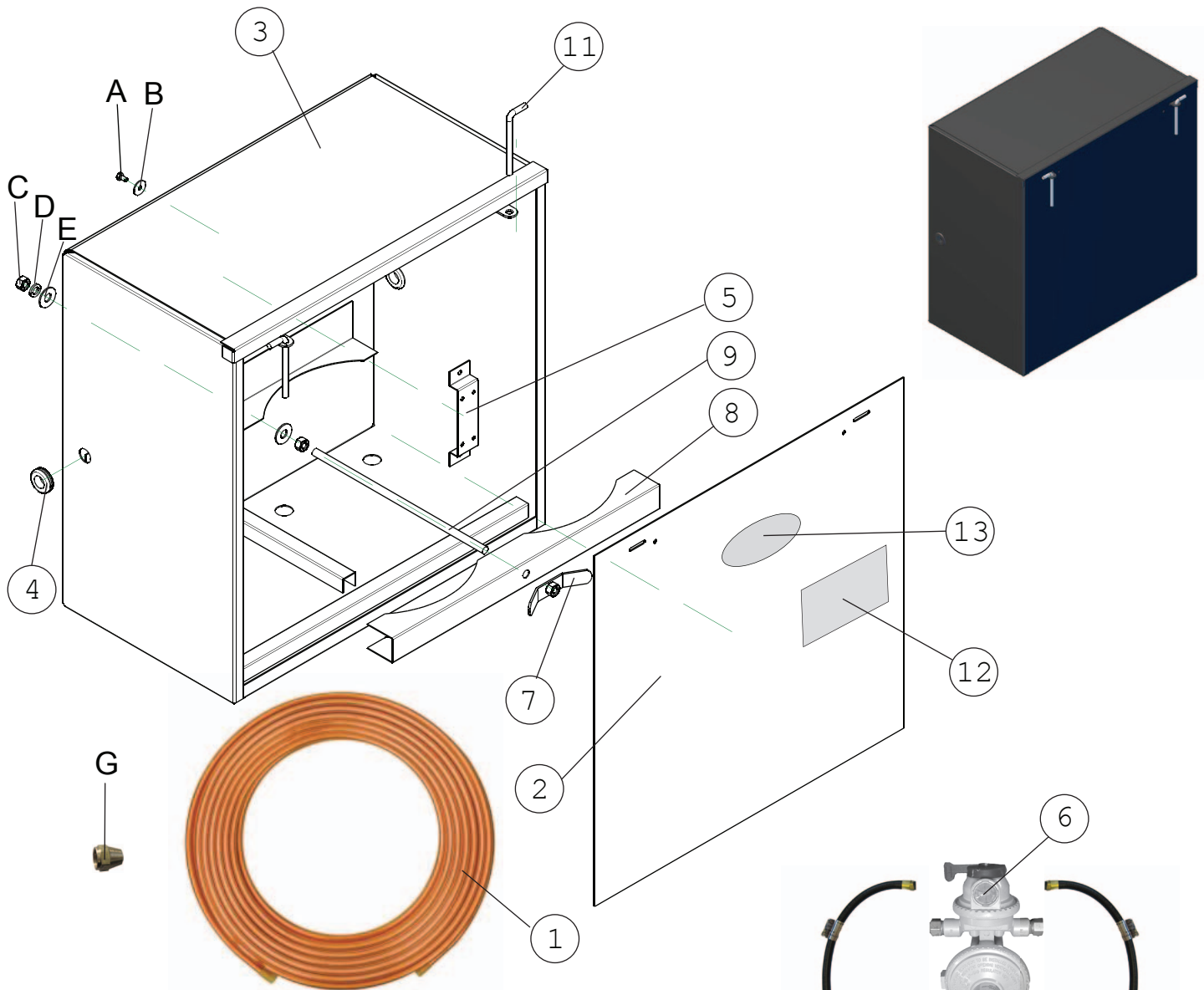

Label	Name	Part #
1	3/8" Copper Tubing - 20 ft	H10-25B
2	X-1050 Door	H10-27
3	Dual Carrier Body	H10-34A
4	7/8" Rubber Grommet	H10-170
5	Regulator Bracket	H10-482
6	Dual Regulator	H10-625A
7	1/2" Butterfly Hold Down Nut	H10-630
8	Bottle Hold Down Bracket	H10-817
9	1/2" Threaded Rod Assy	H10-820
10	Tank Fitting w/ Hose	H10-831
11	Hook & Chain (Not Shown)	H990-09
12	Decal - "Caution on Tanks"	HD-35
13	Decal - "Product of Elston"	SD-02

Label	Name	Quan.
A	1/2" 1/4"-20 Flanged Hex Hd Bolt	2
B	1/4" Flat Washer	2
C	1/2"-13 Hex Nut	2
D	1/2" Lock Washer	1
E	1/2" Flat Washer	2
F	3/8" NPT Male x 3/8" Flare Elbow	1
G	3/8" NPT Flare Nut	2